

LEAD-ACID BATTERY

OBJECTIVE:

You will understand how a lead-acid cell stores electricity and will construct one and use it to demonstrate this property.

INTRODUCTION:

The electric cell is a simple electricity-making unit made of two chemically different metal plates in a jar filled with a liquid that is an acid or an alkali, depending on the type of battery. The metal plates are called *electrodes*. They are conductors through which electricity can enter or leave the cell. The liquid, which must be able to conduct electricity, is called the *electrolyte*. A battery has at least one electric cell, though it may contain several connected in a series. Electric cells produce an electric current because one of the electrodes—the *anode*—gives up its electrons more readily than the other electrode—the *cathode*. When the electrodes are connected in a circuit, electrons flow around the circuit from the anode to the cathode and so produce an electric current.

The earliest battery was made by Italian physicist Alessandro Volta (1745–1827) in 1800. It was made up of several cells of pairs of metallic disks of zinc and silver, separated by moist cloth or paper, connected in a series. Such electric cells are not rechargeable; they eventually run out because of chemical changes in the electrodes and electrolyte. Nonrechargeable batteries are expensive but convenient sources of power for many electrical devices, from flashlights and cassette recorders to watches and hearing aids.

Rechargeable cells, however, can be recharged by applying an electric current to them and so restoring the original chemical balance. This can be repeated many times, so that the battery can be used over and over again as a store of electricity. The lead-acid cell, the oldest and best-known type of rechargeable cell, was developed in 1859 by the French physicist Gaston Planté (1834–1889). Charging the cell using an electric current makes one electrode chemically different from the other—the cathode remains as lead, while the anode becomes plated with lead oxide. This chemical difference between the electrodes generates an electric current when the two are connected in a circuit.

By the 1920s, lead-acid cells connected in a series, also called accumulators, were being used in automobiles and to provide electricity for domestic radio sets. Today, automobile batteries are still used as an energy store to power lights and electrical devices in a car and to provide the spark needed to ignite the fuel. The battery is recharged by a dynamo or alternator connected to the engine. Lead-acid cells also power fork-lifts and provide back-up power in submarines. The rechargeable cells in nickel-cadmium batteries are much more compact and can be used to power small electrical items such as clocks and calculators.

TIME NEEDED:

1 1/4 hours

MATERIALS:

200 ml 2M sulfuric acid	2 alligator clips	2 multimeters
250ml beaker	2 10 cm x 5 cm lead foil	DC power pack
5 60cm lengths of insulated	strips (available from a	stopwatch
bell wire	chemical supplier)	safety gloves
wire strippers	0.2 amp light bulb and socket	safety goggles

Safety Precautions

Adult supervision required. Please read and copy the safety precautions at the beginning of this book. Be careful when handling the sulfuric acid; do not let it come in contact with your skin, clothes, or benchtop. Wear safety gloves and goggles during this investigation.

PROCEDURE:

1. Carefully pour 200 ml of 2M sulfuric acid into the 250ml beaker.
2. Using wire strippers, strip 1 cm of insulation from both ends of all the lengths of bell wire. Attach two lengths of bell wire to two alligator clips.
3. Fold a lead strip over opposite sides of the beaker so that about 8 cm of lead is inside the beaker. Use the alligator clips to clip the folded-over lead strips to the sides of the beaker, as shown in figure 1. The lead strips are the electrodes.
4. Connect one bell wire to the negative terminal of the DC power pack. The electrode connected to this wire is the cathode (negative electrode). Connect the other bell wire to the negative terminal of one multimeter, as shown in figure 1. The electrode connected to this wire is the anode (positive electrode). Connect the positive terminal of the power pack to the positive terminal of this multimeter (multimeter 1) using a third length of bell wire. The completed circuit is shown in figure 1.

Figure 1

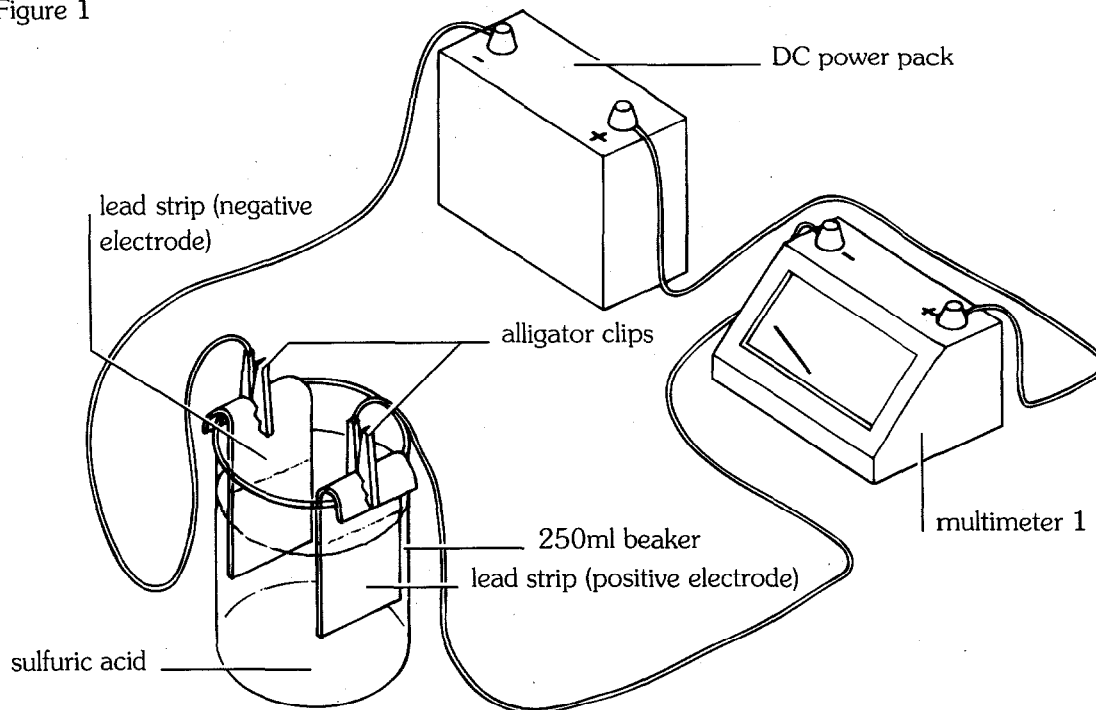

5. Start the stopwatch and at the same time turn on the power pack so that a current of about 1 amp is flowing as measured with the multimeter. Notice the bubbles rising from the electrodes. Record the voltage reading on the power pack.
6. At five-minute intervals check the current flow in amps showing on the multimeter. If the current flow has changed, increase or decrease the voltage until 1 amp is flowing again, and record the new voltage and the time at which you did so. Stop the current flow after twenty minutes and disconnect the alligator clips.
7. Disconnect the power pack and reverse the connections on multimeter 1 as shown in figure 2. Clip the two remaining lengths of bell wire in the alligator clips on the electrodes and connect them to the terminals of the second multimeter (multimeter 2) as shown in figure 2. Note that the cell electrode that was originally the cathode (negative electrode) is now the anode (positive electrode).
8. Connect a 0.2 amp light bulb in place of the original power pack as shown in figure 2. Start the stopwatch and in the first few seconds record the current flow as registered on multimeter 1 and the voltage as registered on multimeter 2. The contents of the beaker act as a lead-acid battery and produce a current which powers the light bulb.
9. Observe the light bulb and multimeter readings for one minute, noting what happens.

Figure 2

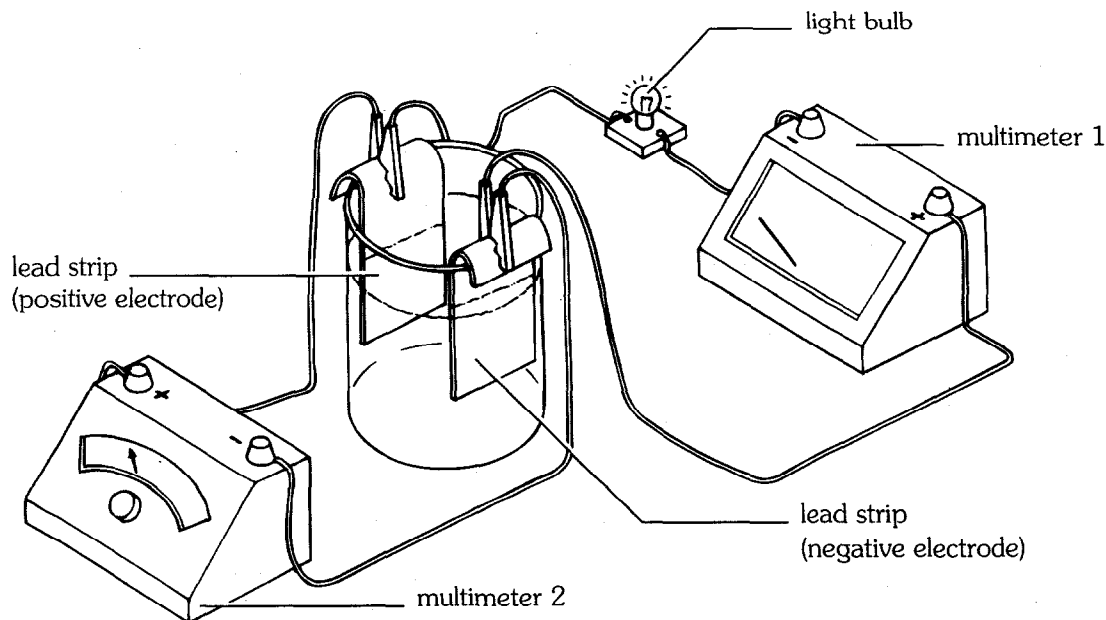

ANALYSIS:

1. In steps 5–6, when the cell is being charged, chemical changes occur at the electrodes. At the cathode (the negative electrode), electrons are gained and lead ions dissolved in the sulfuric acid are attracted and deposited on the cathode as lead. This chemical change is written:



At the anode (the positive electrode), electrons are lost and lead oxide forms. This chemical change is written:

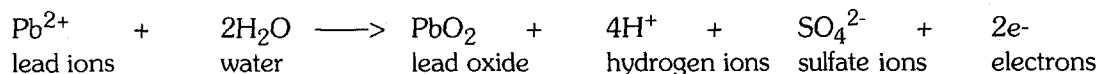

These are not the only chemical reactions occurring. As the current passes through the solution, water is electrolyzed (split by the electric current) and hydrogen gas is given off at the cathode and oxygen at the anode. These gases account for the bubbles given off by the electrodes.

Did one or both electrodes change color? If so, how do you account for this?

2. The power used to charge the battery in steps 5–6 is given by the equation:

$$\text{Power (watts)} = \text{volts} \times \text{amps}$$

The amount of time in which this power is consumed also needs to be taken into account. The equation for this is:

$$\text{Power consumed (watt-seconds)} = \text{volts} \times \text{amps} \times \text{seconds}$$

Using this equation, calculate the power your battery consumed in being charged in step 5. If the voltage was altered during the twenty-minute charging time, you will need to include this in your calculation.

3. In steps 8–9 when the battery is providing power, chemical changes occur at the electrodes. At the new anode (what was the old cathode), electrons are lost and lead sulfate is deposited on the electrode. This chemical change is written:

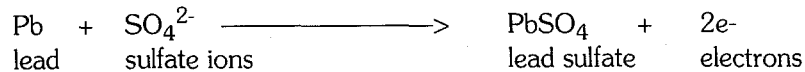

At the new cathode (what was the old anode) electrons are gained and lead sulfate is deposited on the electrode. This chemical change is written:

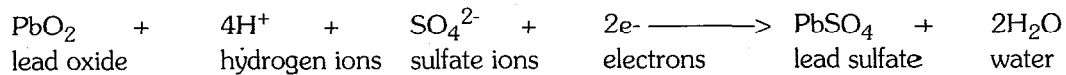

Using the following equation, calculate the power the battery produced in steps 8–9:

Power produced (watt-seconds) = volts x amps x seconds

4. Work out how efficient your battery is—i.e., what proportion of power used in charging the battery is available for use afterward—using this expression:

$$\frac{\text{Power produced (calculated in question 3)}}{\text{Power consumed (calculated in question 2)}} \times 100 = \text{efficiency (as a \%)}$$

Suggest one reason why your battery is so inefficient.

5. In step 7, why are the connections to the multimeter terminals reversed?
6. In step 9, what happened to the power supply and to the bulb? Explain why this happened.

OUR FINDINGS:

See Section X.

SPECIAL SAFETY NOTE TO INVESTIGATORS

Each invention includes any special safety precautions that are relevant to that particular project. These do not include all of the basic safety precautions that are necessary whenever you are working on a scientific investigation. For this reason, it is absolutely necessary that you read, copy, and remain mindful of the General Safety Precautions that follow this note.

Experimental science can be dangerous, and good laboratory procedure always includes carefully following basic safety rules. Things can happen very quickly when you are constructing or demonstrating a model invention. Things can spill, break, even catch fire. There will be no time after the fact to protect yourself. Always prepare for unexpected dangers by following basic safety guidelines the *entire* time you are carrying out the project, whether or not something seems dangerous to you at a given moment.

We have been quite sparing in prescribing safety precautions for the individual projects. We made this choice for one reason: We want you to take very seriously every safety precaution that is printed in this book. If you see it written here, you can be sure that it is here because it is absolutely critical to your safety.

One further note: The book assumes that you will read the safety precautions that follow, as well as those in the box within each project you are preparing to perform, and that you will *remember* them. Except in rare instances, these precautions will not be repeated in the procedure itself. It is up to you to use your good judgment and pay attention when performing potentially dangerous parts of the procedure. Just because the book does not say **BE CAREFUL WITH HOT LIQUIDS** or **DON'T CUT YOURSELF WITH THE KNIFE** does not mean that you should be careless when simmering water or stripping an electrical wire. It does mean that when you see a special note to be careful, it is extremely important that you pay attention to it.

If you ever have a question about whether a procedure or material is dangerous, wait to perform it until you find out for sure that it is safe.

GENERAL SAFETY PRECAUTIONS

Accidents caused by carelessness, haste, insufficient knowledge, or taking unnecessary risks can be avoided by practicing safety procedures and being alert while carrying out these projects. Be sure to check the individual projects in this book for additional safety regulations and adult supervision requirements. If you will be working in a lab, do not work alone.

PREPARING:

- Clear all surfaces before beginning projects
- Read the instructions before you start
- Know the hazards of the procedures and anticipate dangers

PROTECTING YOURSELF:

- Follow the directions step-by-step; do only one project at a time
- Locate exits, fire blanket and extinguisher, master gas and electricity shut-offs, eye wash, and first-aid kit
- Make sure there is adequate ventilation
- Do not horseplay
- Wear an apron and goggles
- Do not wear contact lenses, open shoes, loose clothing, or loose hair
- Keep floor and work space neat, clean, and dry
- Clean up spills immediately
- Never eat, drink, or smoke in laboratory or work space
- Do not eat or drink any substances tested unless expressly permitted to do so by a knowledgeable adult

USING EQUIPMENT WITH CARE:

- Set up apparatus far from the edge of the desk or bench
- Use knives and other sharp or pointed instruments with caution
- Pull plugs, not cords, when removing electrical plugs
- Clean glassware before and after use
- Check glassware for scratches, cracks, and sharp edges
- Clean up broken glassware immediately
- Do not touch metal conductors
- Use only low voltage and current materials such as lantern batteries
- Be careful when using stepstools, chairs, and ladders
- Never look directly at the sun with your observation devices

USING CHEMICALS:

- Never taste or inhale chemicals
- Label all bottles and apparatus containing chemicals
- Read labels carefully
- Avoid chemical contact with skin and eyes (wear goggles, apron, and gloves)
- Do not touch chemical solutions
- Wash hands before and after using solutions
- Wipe up spills thoroughly

HEATING SUBSTANCES:

- Use goggles, apron, and gloves when boiling water
- Keep your face away from test tubes and beakers
- Never leave apparatus unattended
- Use safety tongs and heat-resistant mittens
- Turn off hot plates, bunsen burners, and gas when you are done
- Keep flammable substances away from heat
- Have fire extinguisher on hand

FINISHING UP:

- Thoroughly clean your work area and glassware
- Be careful not to return chemicals or contaminated reagents to the wrong containers
- Don't dispose of materials in the sink unless instructed to do so
- Wash your hands
- Clean up all residue and put in proper containers for disposal
- Dispose of all chemicals according to all local, state, and federal laws

BE SAFETY CONSCIOUS AT ALL TIMES

Our Findings

VIII. ELECTRICITY

8.03 Lead-acid battery

1. The anode (positive electrode) turns brown because of a covering of lead oxide.
2. Results will vary. A typical answer is:

$$\text{Power consumed (watts-seconds)} = 3.8 \times 1 \times 60 \times 20 = 4,560$$

3. Results will vary. A typical answer is:

$$\text{Power produced (watts-seconds)} = 1.9 \times 0.02 \times 30 = 1.14$$

4. Results will vary, but will certainly be less than 0.1%. A typical answer is:

$$\frac{1.14}{4560} \times 100 = 0.025\%$$

Much of the electricity used to charge the battery is lost as heat or is used to electrolyze water to produce the gases oxygen and hydrogen.

5. The connections to the multimeter are reversed because the current flow is now in the opposite direction. The battery which was originally being charged by a power pack is now producing the electric current. If the connections were not reversed, you would obtain a negative multimeter reading.

6. The power supply to the bulb remains fairly stable for nearly a minute and then suddenly drops, making the bulb go out. This is because the battery becomes exhausted and runs out of power.